

Assembly instructions shower temple

D37

(04v24) eng



Attention: Two people should assemble this shower!



Foreword

Thank you for choosing our shower temple. Before unpacking the shower cabin, check the packaging for any damage! Later complaints will not be accepted. Before assembly, also check all parts for damage and for completeness. In case of problems, contact the seller or us promptly! Please read these instructions carefully before you start assembling.

The shower was designed for private use in terms of design and functionality. Our products are subject to constant further development. This may result in changes to the design and the use of other components. We try to stay up to date on the following pages. If you have any questions about the design, please contact us on +49 35795 - 179 600 or by E-mail at kundenservice@seniorbad.de. We are very grateful for any suggestions for improvement.

Build it yourself or hire a craftsman?

Our experience shows that it is possible for any experienced DIYer with a second person to support them to build this shower.

The warranty is not affected by who installs the shower. However, it must be installed professionally according to the specifications in these installation instructions.

You should hire a fitter for the connections. We recommend that you agree on a fixed price. If you do not know a craftsman, ask us. We will be happy to arrange a tradesman who is specially trained in the installation of our showers.

Sealing areas under/behind the shower cubicle

Sealing is mandatory - silicone is not enough!

The surfaces behind and under the shower cubicle must be tiled. Sealant joints - such as silicone joints - are not seals, but only maintenance and beauty joints! Only the use of tub sealing tapes or e.g. sheet sealants comply with this DIN.

Waterproofing according to DIN 18534

„This standard is therefore not only addressed to the waterproofing specialist, but also to those who are responsible for the overall planning and execution of the structure and its components, because the effect and durability of the waterproofing depend on the coordinated planning of all parties involved“.

As an installer, you are responsible for reliable sealing, alongside the planner and tiler.

„The waterproofing must fulfil its function with sufficient reliability for the intended service life.“

Waterproofing must be planned in such a way that it functions for the entire duration of use. In a domestic bathroom, this can be an average of 20 to 25 years. In practice, this means that tiles or a waterproofing membrane must be laid under the bathtub. Note that the sealing area at the transition from the floor to the wall must be at least 10 cm high.

Electrical parameters

Rated voltage	Frequency	Total consumption	Lighting
230V	50/60Hz	31W (with steam 3031W)	10W
Fan	Radio	Radio frequency range	(steam generator)
6W	15W	88-108MHz	(3000W)

Tips for the E-connection

Electrical work in the bathroom must be carried out by qualified personnel! They must also ensure adequate earthing to prevent accidents and malfunctions.

- The power supply should be provided via a separate circuit -> 230V +10%, 50Hz 16A, with a cable cross-section $\geq 1.5\text{mm}^2$ (for showers without steam function 0.75 to 1.5mm^2). In accordance with legal requirements, sockets in bathrooms must be protected with a residual current circuit breaker.
- The shower must be well earthed and connected to the potential equalisation in the bathroom.
- It is strongly recommended that the socket for the shower can be switched on and off individually. The shower should be able to be switched off via an external switch, e.g. next to the shower or in the fuse box.
- Please have an electrician regularly check the function of the residual current circuit breaker.

Tips for the water connection

- The water pressure should be 0.2 - 0.4 MPa (2-4 Bar), if the pressure is higher, a pressure reducer must be connected upstream.
- The water temperature must not exceed 65 degrees Celsius.
- It should be possible to turn off the water supply for the shower separately, e.g. with ball valves.

Attention: This shower is not intended for permanent installation. This is important in order to be able to decalcify the steam generator later on without great effort or to access other assemblies. It must be ensured that the complete shower cubicle is installed in such a way that it is freely accessible for any maintenance or repair work. It must be ensured that the floor of the bathroom is completely tiled and that a floor drain is available. It is not necessary to tile the walls behind the shower enclosure. The shower tray must not be sunk into the floor!

Safety instructions

- Electrical appliances may not be brought into the shower!
- The shower may only be used by children under the supervision of an adult and the supervisor must be familiar with the use of the shower.
- The shower may not be suitable for people suffering from poor circulation, asthma, hypertension or heart disease. If you are unsure, seek advice from your family doctor. Do not topple or stack the appliance during storage.
- Never store together with organic solvents such as formaldehyde. Store in a dry and cool place.
- Do not store outdoors.
- We recommend thorough cleaning and a test of all functions before using the shower. Familiarise yourself with the operation BEFORE use!
- After a long period of inactivity, rinse the pipes of the head, body and hand shower as well as the foot massage (*depending on the model) with hot water by opening the tap.
- The mains switch must not be pressed while the steam shower is in use to prevent the automatic water drain from being activated, otherwise there is a risk of scalding!
- Ensure that elements susceptible to limescale are regularly maintained, cleaned and descaled. Please ensure that the steam outlet filter is cleaned and descaled separately. To do this, remove the protective cap and pull out the sieve. Carry out these activities regularly depending on your shower behaviour and the hardness of the shower water. This will prevent heat build-up and damage to the surface. Maintenance should be carried out by specialised personnel. Please also refer to the instructions for descaling the steam generator at the end of these instructions.

Tools for the construction

Tools not included in the package.

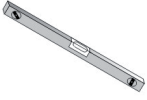

Spirit level



Drilling machine



Measuring tape



Phillips/flat-head
screwdriver



Open-end spanner

Product components

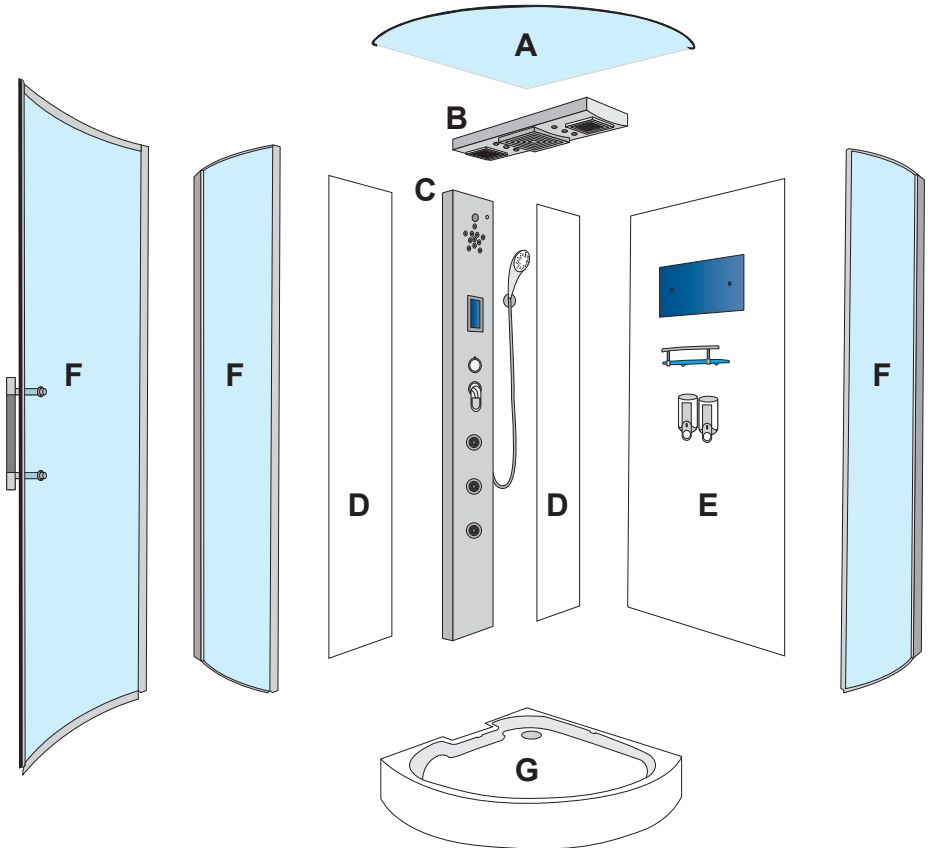

A Glass cover

B Ceiling panel: with integrated fan, loudspeaker, rain shower and LED recessed spots with colour changer.

C Shower panel: equipped with back massage, fittings, lighting, ozone generator and control display. In addition, the control electronics and the steam generator are mounted from behind. The shower panel is only pre-assembled at the factory to make it easier for you to assemble. You must check all screw connections and tighten them if necessary. This applies to the nozzles and the clamps.

D Left partial rear walls: pre-assembled with aluminium profiles.

E Right rear wall: to be fitted with glass shelf, soap dispenser and mirror.

F Front panel: consisting of 2 side panels and 1 glass door.

G Shower tray: with reinforced frame, fitted with the drain.

H

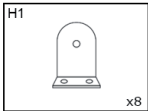

Angle shower tray

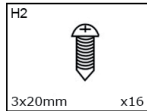

Sheet metal screw

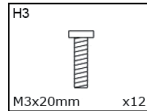

Screw

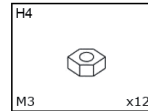

Nut

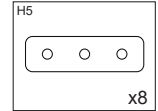

Gasket angle shower tray

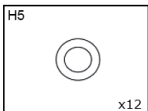

Washer metal small

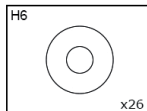

Silicone washer

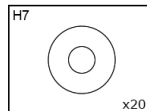

Washer metal large

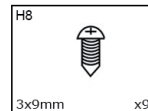

Sheet metal screw

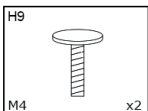

Lock bolt for mirror

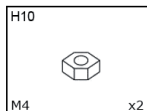

Nut

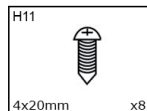

Sheet metal screw

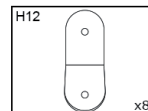

Angle cover

Check completeness!

Please check for completeness. If you do not find something immediately, please look again carefully. Small parts in particular are easily overlooked due to the large number of parts and the mass of the packaging. Please do not dispose of the packaging until you are sure that it does not contain any small parts

Connections for water, sewage, electricity, telephone

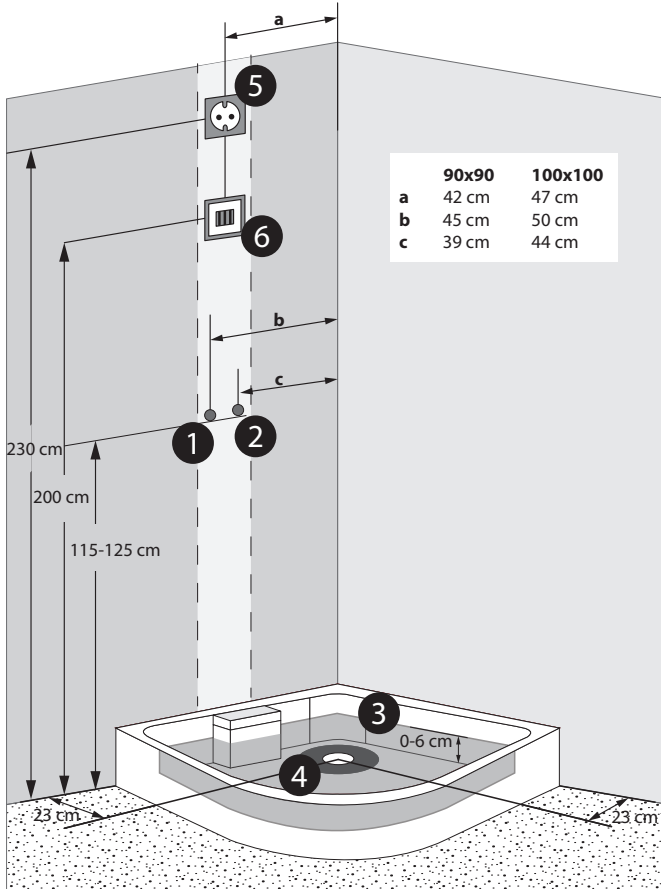

- 1
 Hot water 1/2 inch
- 2
 Cold water 1/2 inch
- 1-2
 Connections can also be on the opposite side
- 3
 Grey area = possible area for the drain pipes, in the wall area the drain can be up to a max. height of 6 cm from the centre of the hole.
- 4
 Waste water is connected via a HT 40 flexible hose (supplied).
ATTENTION: leave an area of 15 cm diameter free in the connection area of the white siphon (dark grey area) on the underside of the shower tray.
- 5
 230V 16A socket outlet (or fixed socket outlet)
- 6
 Telephone socket

Setting up and aligning the shower tray

Place the shower tray where you want it to stand later. Align the shower tray with the help of a spirit level.

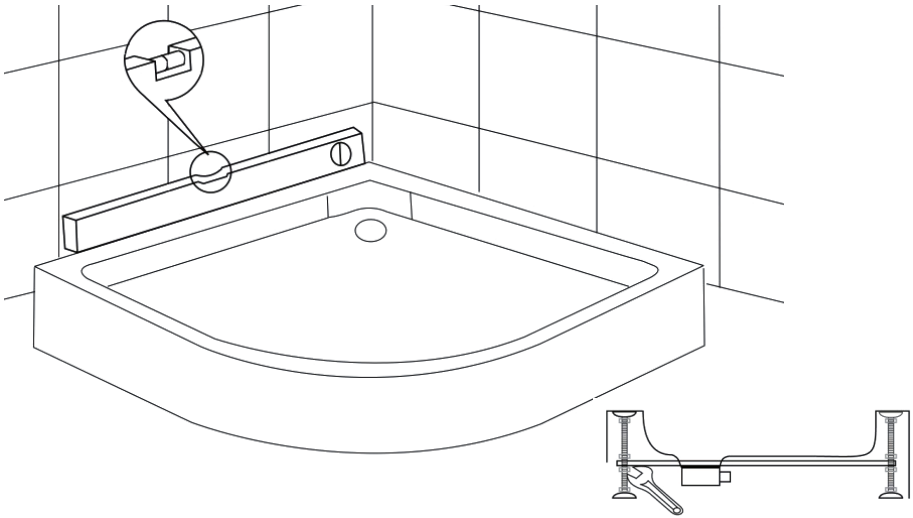

You can adjust the height of the individual feet. It is very important that the shower tray stands straight, does not tilt and that all feet are on the floor. Now check whether the water drains well. Please take some time to do this.

Now pull the shower tray about 40-50 cm out of the corner to give yourself enough space to build the shower.

Attention: The drain has a connection for the residual water drain of the steam generator. If you have ordered a shower with a steam generator, open it inwards with a 5mm drill bit so that the residual water can drain off (this only applies to models with a steam generator). You must never do this if you have bought a shower without steam!

TIP:

To make it easier for you to push the shower tray into the corner after assembly, we recommend that you apply a lubricant (e.g. a washing-up liquid) to all feet. Then it will „glide“ much better on the tiles.

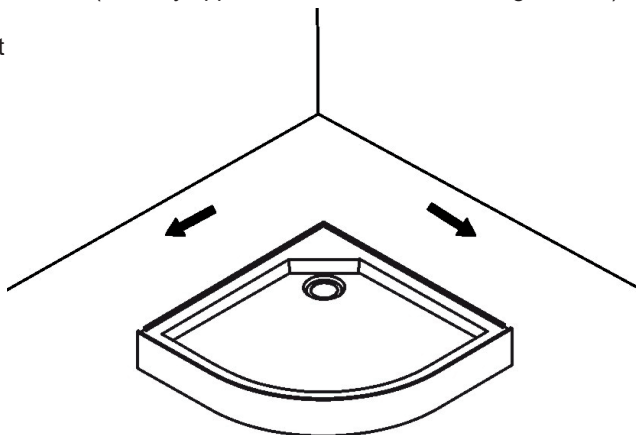

Prepare the rear walls for assembly

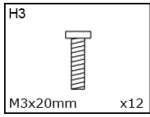

Screw

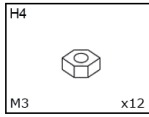

Nut

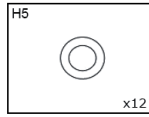

Washer metal small

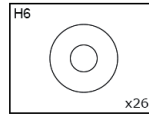

Silicone washer

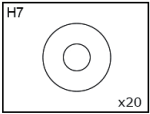

Washer metal large

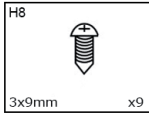

Sheet metal screw

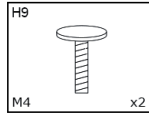

Lock screw for mirror

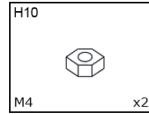

Nut

Mount all add-on parts such as mirror, soap dispenser, glass shelf, hand shower holder, etc. on the back walls BEFORE you place the walls on the shower tray. This saves a lot of time during the final assembly of the cubicle.

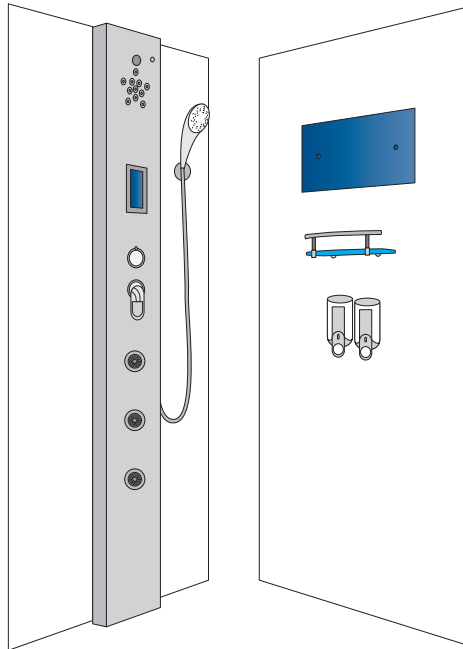

All holes in the rear walls, as well as in both panes of the front, in the door and in the lid, are a few millimetres larger than the screws. Don't worry, this is deliberate. It creates enough space to be able to align the individual elements optimally. **Only when the shower has been completely assembled and aligned and all seals have been fitted may the screw connections be tightened!**

Connecting the back panel with the panel

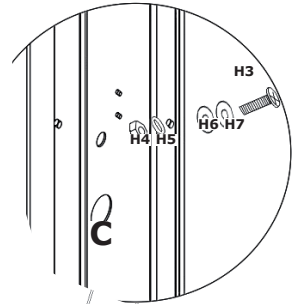
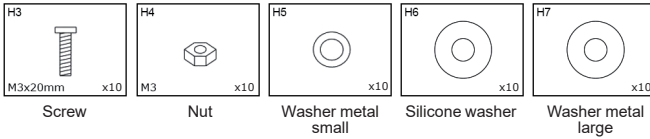

The two narrow partial rear walls D are connected to the shower panel C.

Stick the joint sealing tape, rear D on the panel along the middle edge, approx. 3 mm from the outer edge.

Now take the screw H3, first put on the large metal washer H7 and then the silicone washer H6. Now push the screw through the hole in the glass back panel and the plastic panel (the silicone washer must lie on the glass). From the back, put the small metal washer H5 on top and the nut.

The screws are not yet tightened completely. This is done after the final alignment of the shower.

H-pane seals are fitted at the top and bottom of all rear panels and on both panes of the front. These must be fitted BEFORE the glass enclosure is installed. The H-pane seals serve to seal the shower tray and the lid.

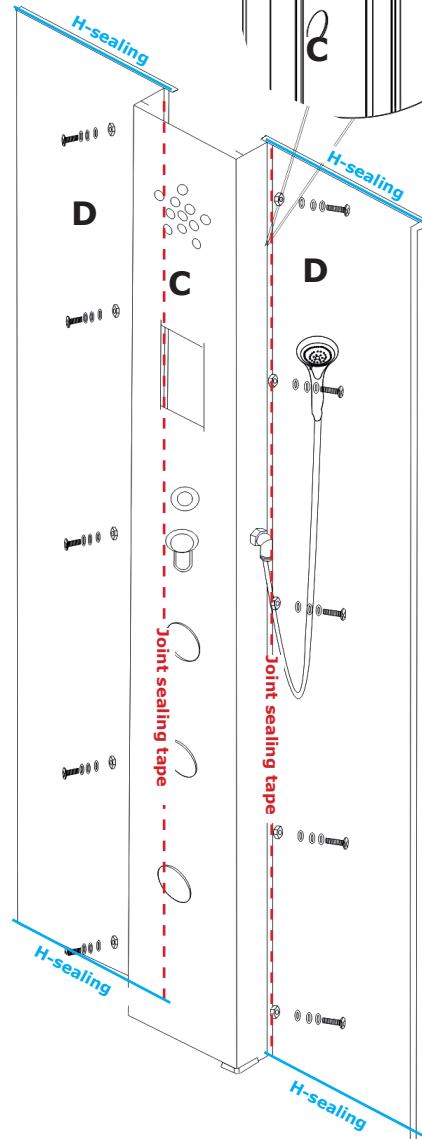

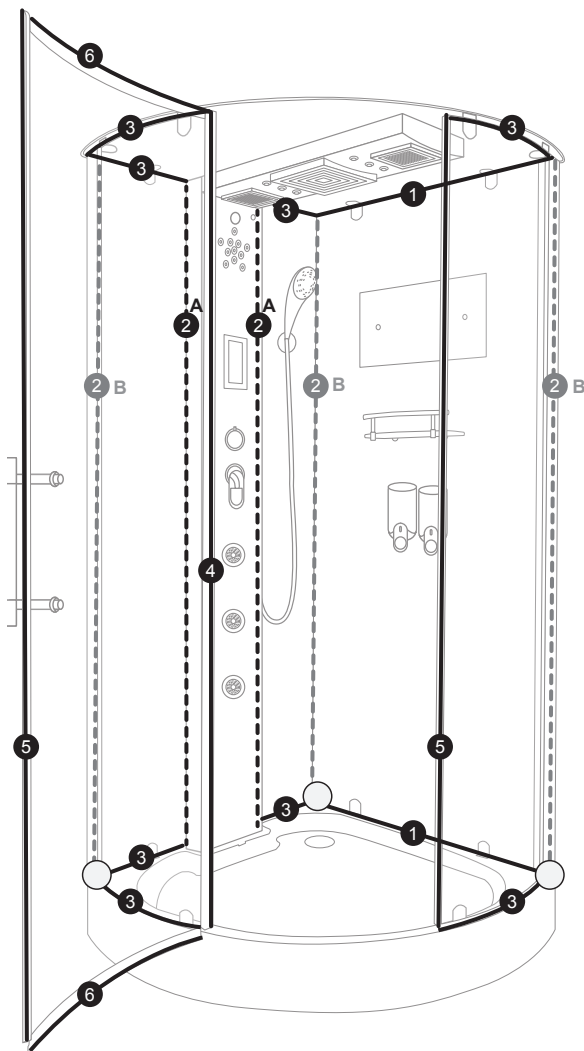

Seals

Below you will find a small overview of where the seals are fitted. The H-seals (1 - long and 3 - short) are only fitted at the top and bottom of the side windows and rear walls. The same applies to the door seal (6). The h-sealing lip (4) goes on the hinge side of the door. The magnetic strips (5) are used to close the door and are placed at the door opening. The joint sealing tape (2) must be fitted between the panel and the rear walls and can be glued into the corner joints between the remaining profiles (see tip on page 11).





- 
1 **2 H-seals**
 - 2 for the back wall

- 
2 A **A Joint sealing tape**
 - Self-adhesive
 - Stick between the panel on the back wall

- 
2 B **B Joint sealing tape**
 - Self-adhesive
 - Between the profiles (as an alternative to silicone, see tip on page 11)

- 
3 **8 H-disc seals short**
 - 4 for the windscreen
 - 4 for the narrow back panels

- 
4 **h-sealing lip**
 - On the door -> hinge side

- 
5 **Magnetic strips**
 - At the door

- 
6 **2 W seals**
 - On the door at the top and bottom

Profiles are shown in cross-section)

TIP:

The corners on the Shower tray, should among the profiles with some silicone out-be filled.

Screwing the back panels, shower tray & front panels together

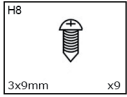

Sheet metal screw

It is very important that the H-pane seals are fitted to the rear walls, the side windows and the front window before assembly.

The seals are slightly longer and must be shortened to the exact length with a knife. They must not be cut too short because they must reach flush to the corner profiles.

Now place the rear and side walls on the shower tray. First place the right rear wall with the mirror on the shower tray. This **MUST** be held by a helper!

Now place the left-hand rear wall consisting of two panes and the panel on the shower tray. Both back walls are screwed together.

Make sure that they are 100% perpendicular! Only then the corner profiles are screwed together with 3 small self-tapping screws H8. Check with a spirit level that both rear walls are exactly perpendicular. Now tighten the self-tapping screws.

Then fit the side windows. Proceed in the same way as described above. Please make sure that the panes are

100% perpendicular before you screw the corner profiles with the small sheet metal screws.

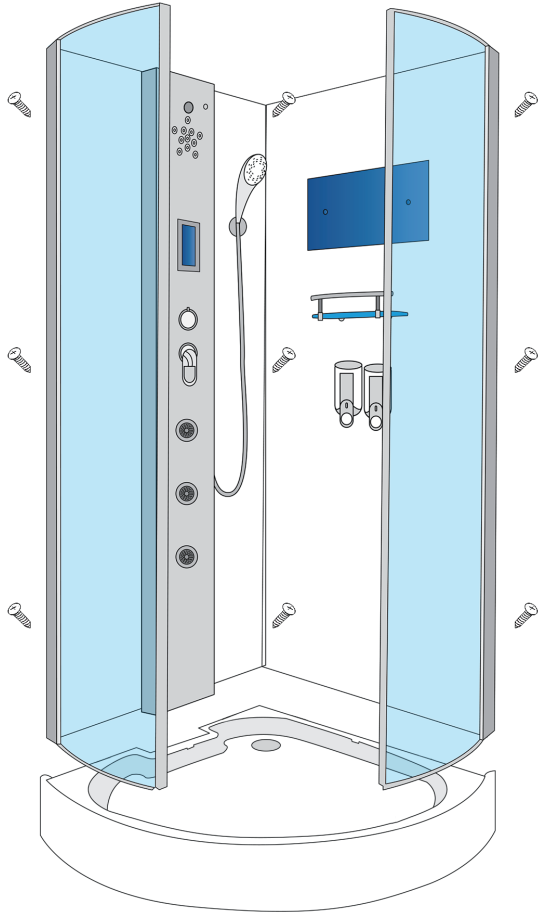

TIP:

*So that you do not have to make a silicone joint in the corners of the side windows later, we recommend that you apply a very thin and even layer of silicone between the profiles **BEFORE** fitting them together. As an alternative to silicone, you can also use the joint sealing tape supplied. The advantage of this is that it is easier to dismantle the cabin later, but you need more force to press the sealing tape together in the profiles when joining the rear walls.*

Attaching the cover

The following drawing shows you how to place the cover on the shower enclosure and connect it with the help of the brackets. The holes provided for this purpose have already been pre-drilled.

Now screw the brackets for holding the glass lid together with the back panels, as shown in the picture.

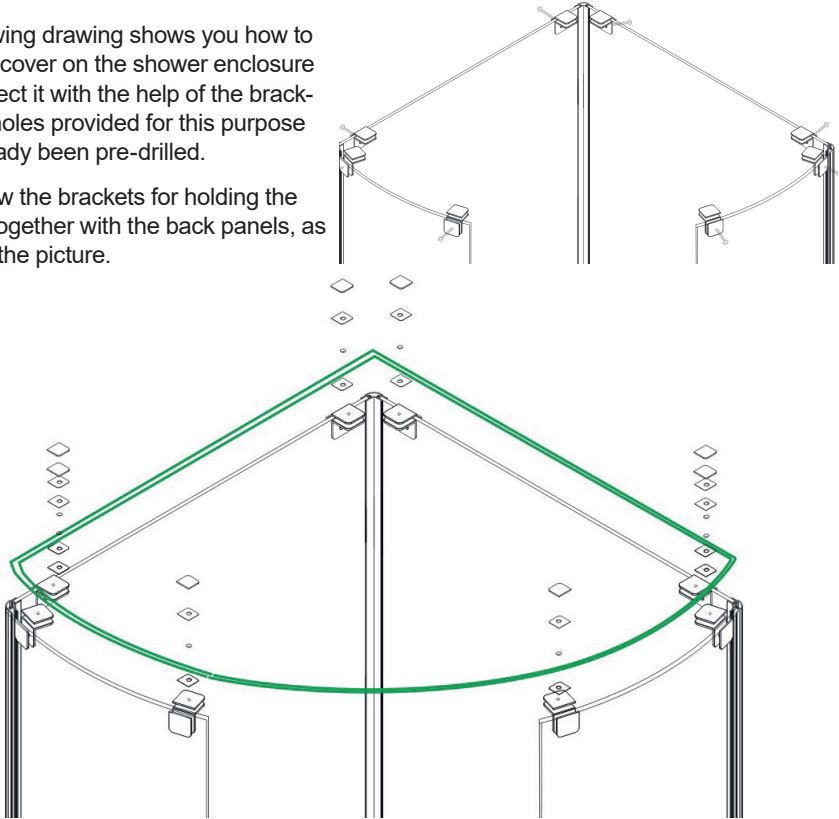

The basic body of the shower is finished. The walls stand firmly and securely, nothing can fall over. Now just tighten all the Allen screws.

Now that the cabin is completely standing, screw the top panel to the lid. Unless you have too little room height to screw the panel tight from above. In this case, attach the panel to the lid before screwing the lid to the shower enclosure.

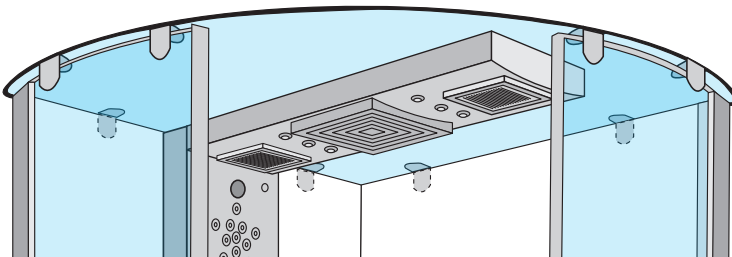

Fitting the glass door

Now start fitting the magnetic catches. One goes on the left side wall and one on the left of the door.

Two H-seals need to be shortened to the width of the door and then fitted to the top and bottom of the door.

When all this has been prepared, you only need to screw the door to the side wall with the hinges provided.

When fitting the door, the Allen screws should also not be tightened at first. Only when everything has been screwed on correctly and the door is roughly aligned, tighten one Allen screw per hinge slightly. Now the door is aligned again before all the Allen screws are tightened.

It has proved useful to align the door with the help of two wooden wedges. These are clamped between the door and the shower tray. This way you have one hand free to tighten the screws.

To ensure that the door closes properly, the shower must be exactly level. Please also align the magnetic strips exactly. Finally, fit the door handle. If your door opens in the opposite direction, please carry out the steps the other way round.

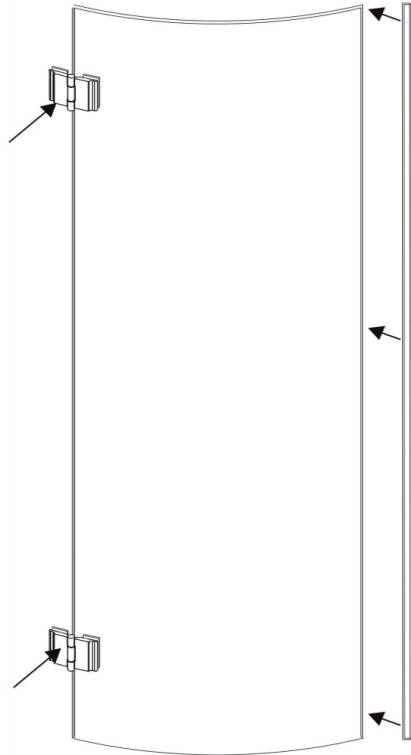

TIP: *It is possible to unscrew the bolt that connects both parts of the hinge. The hinge now consists of two individual parts. You attach one part to the door and the other part to the side window. Now simply hold the door against the shower and insert both bolts into each other and screw them together.*

Screwing the cabin to the shower tray

Only when the door is precisely aligned and can be opened and closed easily do you start to firmly connect the shower walls to the shower tray.

The drawing shows where the glass cubicle is screwed to the shower tray using the metal brackets.

The Allen screws of the brackets should not yet be tightened completely so that the glass cubicle can still be moved a few millimetres. This applies to the bottom as well as the top. Only when the cabin, consisting of shower tray, glass structure and cover, is completely assembled and aligned are the screw connections tightened.

Attach the brackets

Now screw the H1 brackets into the shower tray. The corresponding points are already marked for orientation. Place the enclosed seals H5 between the brackets and the shower tray.

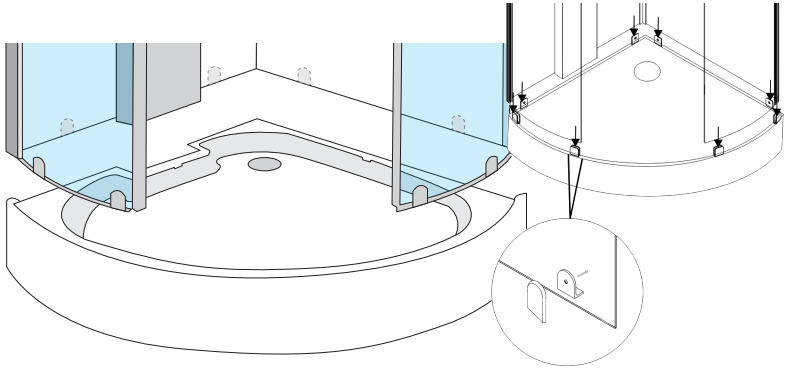

Now align the glass cubicle exactly on the shower tray. It is important that all glass sides are aligned 100% parallel to the associated edge of the shower tray. The rear panels must have a distance of approx. 3.5 cm to the outer edge of the shower tray wall. For the front panels, this dimension is approx. 2 cm. Depending on how you have set up the cubicle and aligned it within itself, there may be a small deviation of approx. 1-3 mm in these two measurements.

Now hold the metal brackets at the places where they are to be screwed and check whether the markings fit. If the deviations are greater than 4 mm, the alignment of the glass cubicle on the shower tray must be checked again and changed if necessary. If the markings match, you can now drill the holes for the screws with a drill bit of about 2.5 mm. The holes for the metal brackets in the glass are slightly larger in order to have more room to adjust the angle.

Once the holes have been drilled, the glass cubicle is aligned one last time and connected to the shower tray with the metal bracket.

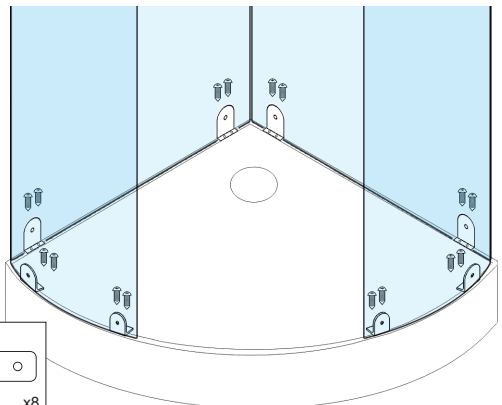
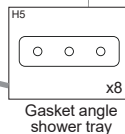
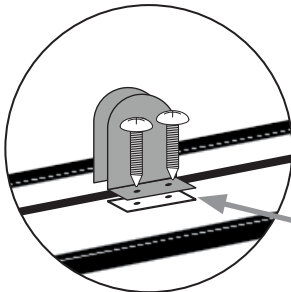
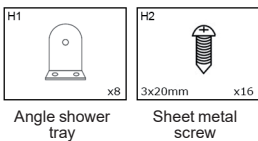

Connect cable connections

The wiring of the shower is quite simple. All connections that are to be interconnected are marked with small stickers. For example, „Speaker“ is marked with „Speaker“ connected.

Wiring diagram without steam function

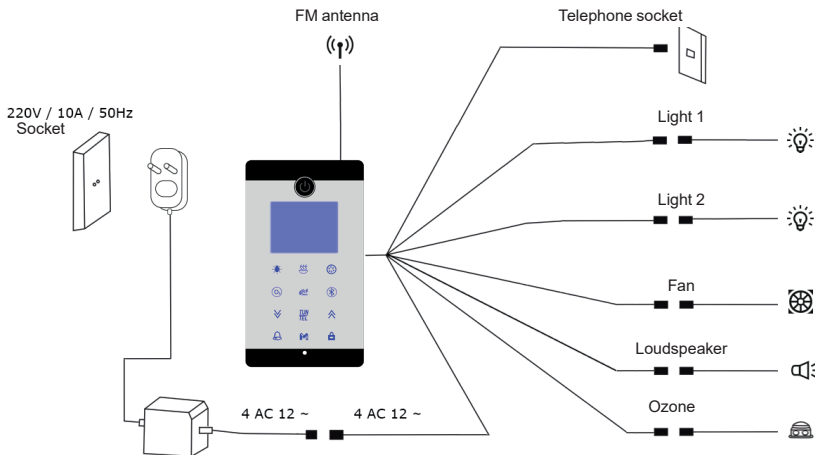

Special features shower with steam function

The control unit is connected to the control unit (box at the back, top of the panel) via the 9-pin **data cable „B“**.

Wiring diagram with steam function

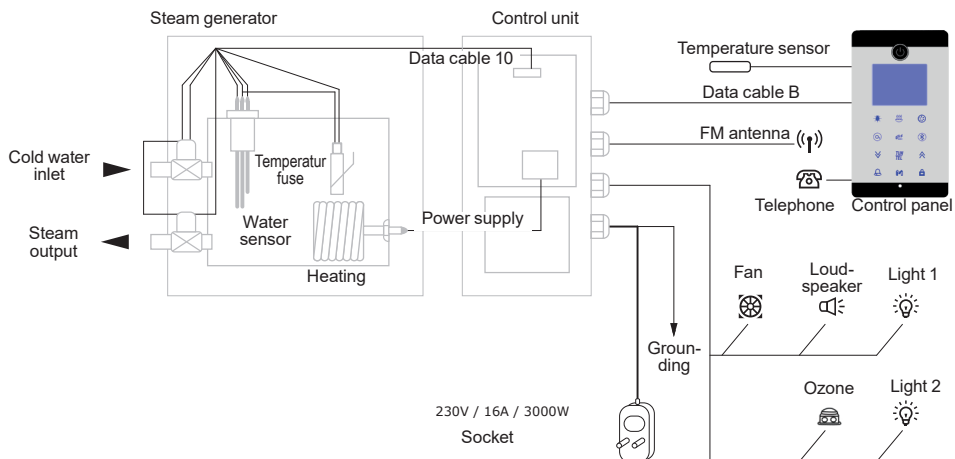

The steam generator is connected to the control unit with the 3-pole power cable (the only cable that carries 230V, all others only carry 12V) and is then also connected to the control unit with the 9-pole **data cable** „10“.

The temperature sensor

The temperature sensor is attached to the aluminium panel, approx. 5 cm below the lid, but above the panel lighting. The corresponding socket is already mounted in the panel. Push the sensor from the back approx. 3mm forwards through the panel so that the room temperature can really be measured exactly. Now fix the sensor with a little silicone.

Hose connections

The sketch shows an overview of the water connections, these are located behind the Shower panel.

View of the connections from behind

Single-lever connection

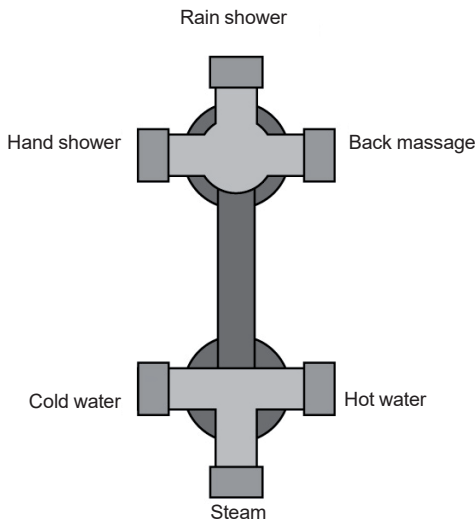

Now connect the hoses for the individual functions to the four-way distributor at the top of the fitting. Starting at the top and then going clockwise, connect the hoses in the following order. First the rain shower, then the back massage, then the bath spout and finally the hand shower. The armoured hoses for the shower water supply come to the dual connection at the bottom, with the cold water on the left at the blue point and the hot water on the right at the red point.

TIP: *The metal armoured hoses for hot and cold water must be connected to the fitting with the angled side (90° bend)!*

Thermostat connection

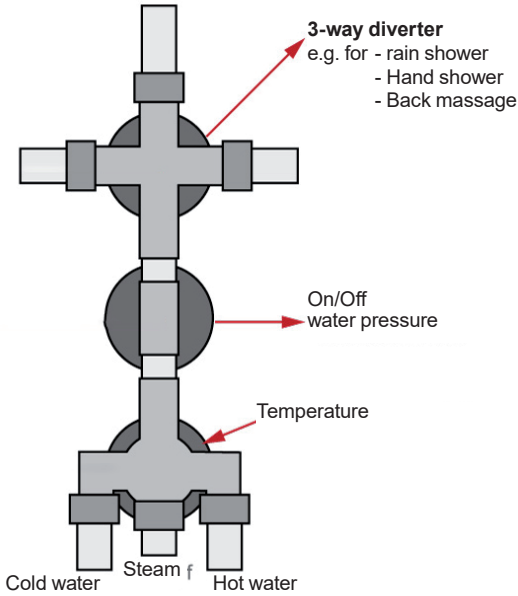

Special features shower with steam function

The water connection for the steam generator is made directly via the fitting.

Please be sure to connect the cold and hot water supply lines according to the colour marking! Incorrect connection may result in damage to the steam generator

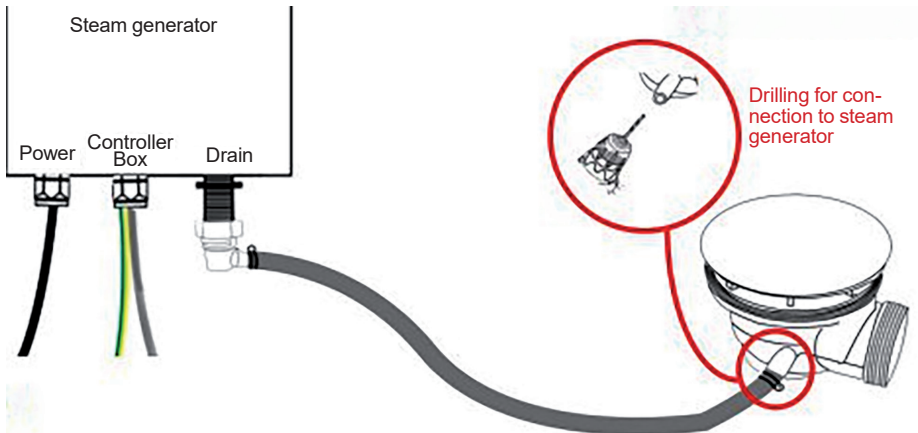

The illustration shows the connection of the drain to the steam generator.

Notes on the use of the shower cubicle

Version with single-lever mixer:

To open the water in the shower, pull the single-lever mixer towards you. You can set the water temperature by turning it to the left and right. The water selector switch is located above the single-lever mixer and allows you to switch between rain shower, hand shower, back massage and foot massage.

Version with thermostat fitting:

There are three dials on the thermostatic mixer. The 4-way switch is located at the top. With this you can choose between rain shower, hand shower, back massage and foot massage. With the middle knob, you open and close the water and regulate the amount of water. The lower knob is for setting the water temperature. If you want to set more than 38°, please press the safety button, but **WARNING: Danger of scalding!**

Use of the odour trap

During the shower, please pull off the silver cover in the shower tray (odour trap) to ensure better water drainage. After the shower, close the opening again with the odour trap.

Ozone cleaning for showers with steam function

The ozone should be switched on once or twice a week. You can activate this by pressing the „O3“ button on the display after taking a shower or sauna. Important: To be able to switch on the ozone, all other functions such as steam, radio, light, etc. must be switched off. Let the ozone cleaning run for 5 - 10 minutes with the doors closed and then switch off the entire shower.

Ozone cleaning for showers without steam function

As soon as you switch off the control panel after showering, automatic ozone cleaning begins. Please keep the doors closed during the process. The display remains dark during cleaning, only the control panels remain lit. After approx. 5 minutes the cleaning is finished and the display switches off completely.

The coloured light therapy

The coloured light spots are located in the lid, mounted to the left and right of the ozone generator. You achieve the most positive effect when the light in the bathroom is reduced and the shower is filled with steam. In 5 to 6 seconds mode, the spots change their colours.

If the colour spots are out of sync and run differently, switch the colour light OFF briefly and then ON again.

Aromatherapy

Aromatherapy is only available in the showers with steam generator. Take a small, heat-resistant cloth (e.g. linen or cotton) measuring approx. 5x5 cm and drip 2-4 drops of our highly concentrated aroma oil onto it. Now push the steam head upwards and insert the cloth (the steam head is the small white box at the bottom of the aluminium panel, approx. 30 cm below the seat). Under no circumstances should the steam head be blocked with a cloth that is too large! Also avoid touching the steam head during operation or refilling it with oil, there is a high risk of burns!

Aromatherapy fragrance set

The essential oils are manufactured according to strict quality standards. All oils are 100% natural and of plant origin, unchanged, pure and authentic!

Attention:

use only 1-2 small drops at a time, the oils are highly concentrated! Please DO NOT use if you are pregnant!



Peppermint Fragrance Oil 10ml

- Eliminates fatigue, overwork and drowsiness
- Helps with vomiting and diarrhoea
- Helps with mental exhaustion
- Increases the ability to concentrate
- Strengthens the memory



Menthol Fragrance Oil 10ml

- Suitable for healing burns and sunburns
- Improvement in acne, abscesses and eczema
- Promotion of cell regeneration
- Improvement in bronchitis and asthma
- Promotion of stomach functions
- Has a disinfecting effect



Lime Fragrance Oil 10ml

- Improvement for oily skin
- Cleanses the skin
- Helps against corns
- Promotion of blood circulation
- Alleviation of anaemia
- Reduce headaches
- Prevents infections
- Promote digestion



Order „Aromatherapy Fragrance Set“ at:

E-mail: kundenservice@seniorbad.de

Online shop: www.seniorbad.de

Phone/Fax: +49 35795 - 179 600/ +49 35795 - 179 699

Sealing

Now draw a narrow silicone joint between the shower tray and the mounted glass walls from the inside. Make sure that the drainage is never closed with silicone, it **MUST** remain open!

Every time you turn off the shower, you will notice that about half a litre of water drains out of the drainage (if the steam generator is very hot, it is also times a little more). This is not a malfunction or leak, it is the residual water emptying of the steam generator. This prevents old water from remaining in the generator and stagnating.

You can also draw a narrow silicone joint around the metal angles at the bottom. Please use sanitary silicone and a silicone remover with a radius of 4 mm.

Commissioning / leak test

For the leak test, please now connect the water and the waste water with the hose connections. It is important that the shower continues to stand away from the wall so that you can still get behind the shower enclosure.

Before putting the pipes under water pressure, please note that the shower panel has only been pre-assembled at the factory to make installation easier for you. It is absolutely necessary that you check all screw connections and tighten them if necessary. This applies to the seat, the nozzles and the clamps. Only when you have checked everything may you open the water.

Now test all the functions that have to do with water, one after the other. Check the hand shower, then the rain shower, the back massage and the foot massage. It is best to check this in pairs. One stands in front of or inside the shower cubicle, the other stands behind the shower cubicle and checks the hose connection and the water flow.

their function, which is being checked in each case. If a screw connection is not properly tight, check whether the seal in the screw connection is properly seated and whether it is screwed tight enough. After the leak test, the electrical functions can now be checked. When the plug is inserted, you can test the light, radio, steam function, etc.

Using the control panel

Shower with steam function

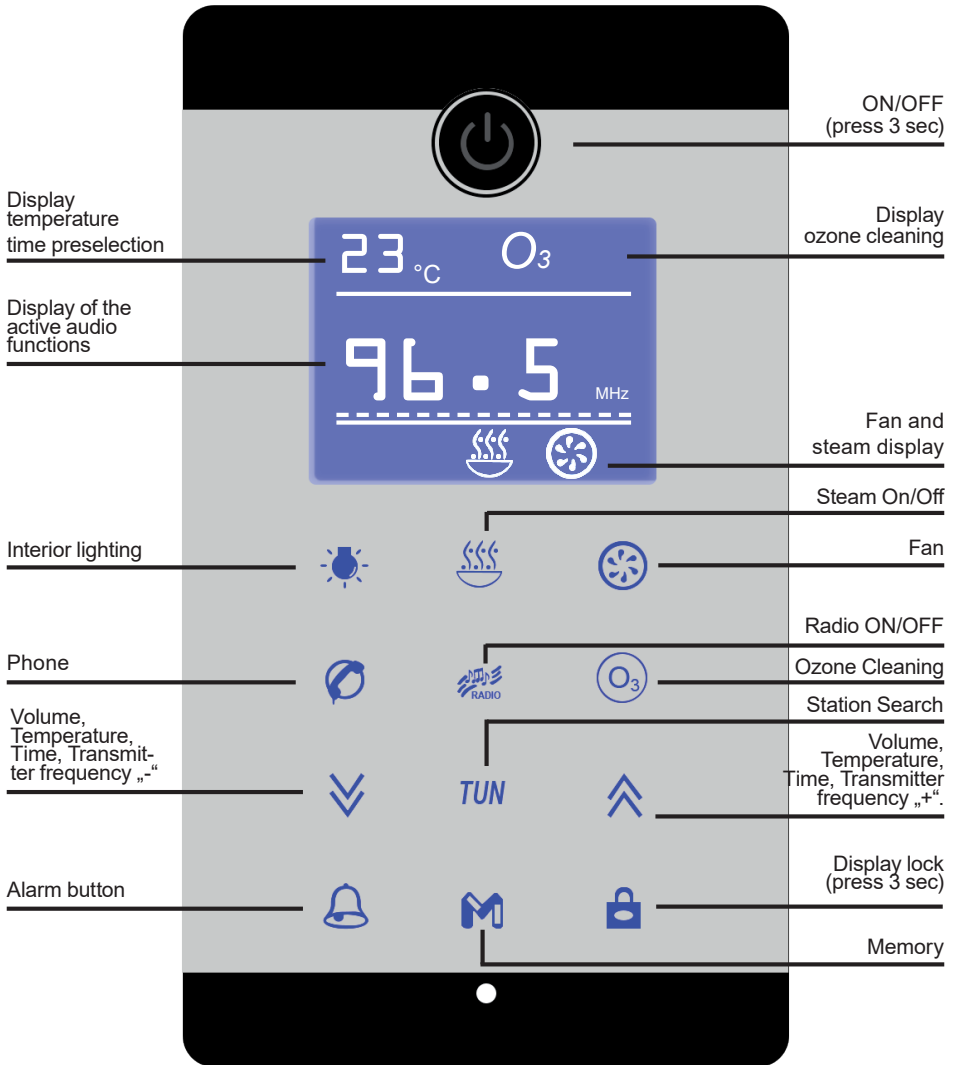

Display key lock

Please note that when switching on, the key must be pressed until the signal tone sounds. Only then can you operate the other keys. After a relatively short time, if you do not operate the display, the key lock switches on automatically. You can also hear this by the emitted Beep.

Shower without steam function

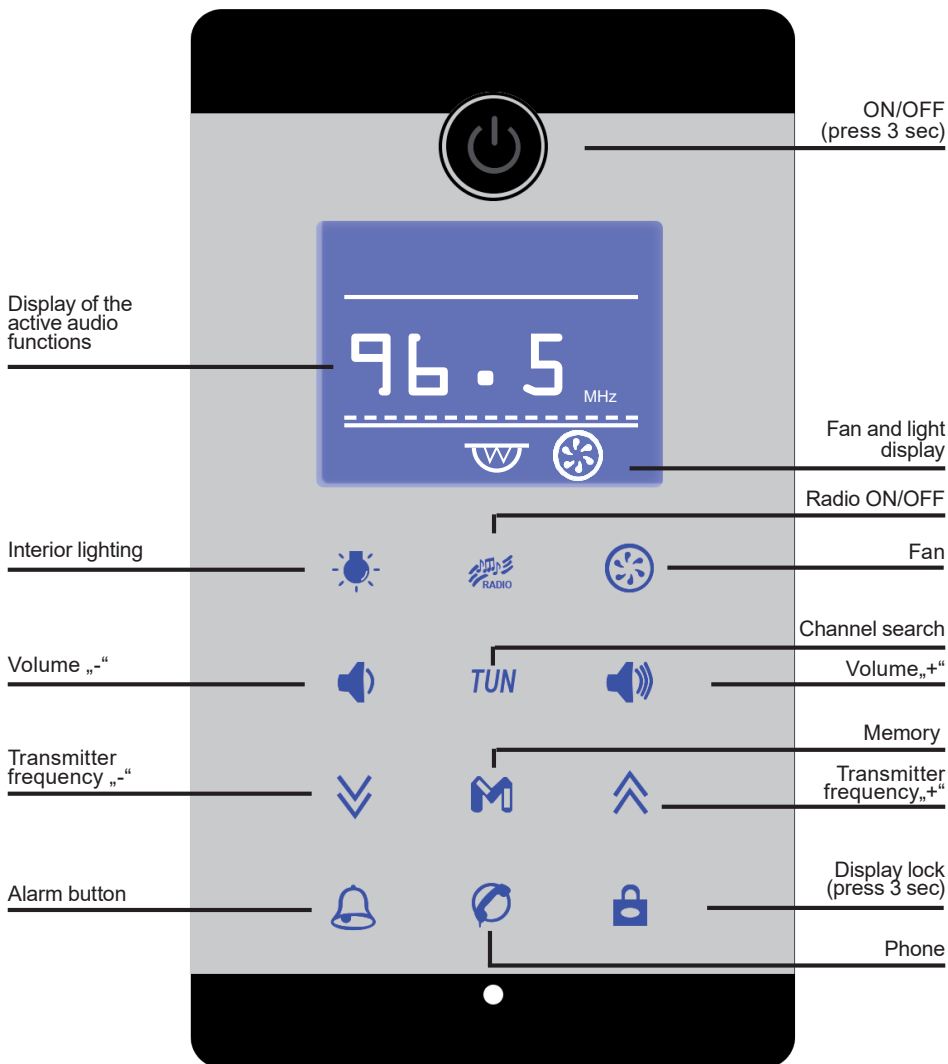

In order to be able to operate the display again, it is necessary to press the lock symbol (bottom right in the picture) until a signal tone is also heard here. Only then are the keys „released“ again and you can operate the keys.

Please note that it is not sufficient to tap the key lock briefly (light goes on). You must wait until you hear the signal tone!

Shower maintenance and cleaning

- Clean the shower enclosure with a mild liquid detergent and a soft cloth. Caution: Never use acetone, cleaning agents containing ammonia or coarse-grained scouring agents!
- Regularly clear the shower drain of hair etc. to prevent clogging.
- Use an acrylic care product for the shower tray and the panel to protect the surface from scratches.

„Lotus -Effect Set“ Put an end to dirt deposits, limescale/water stains!

Content:

- 1x NANO NT GLASS & CERAMICS (easy to clean)
- 1x NANO NT CLEANER
- 1x CLEANING WIPE
- 1x POLITURE CLOTH
- 1x PROTECTIVE GLOVES



Resistant to steam cleaners * Very durable long-term protection * Lasts for many months, depending on use * Minimal care and cleaning effort * No expensive cleaning agents required * Dirt can no longer adhere firmly or is easier to clean (easy-to-clean) * Very easy to handle

THE NANO NT GLASS & CERAMICS 2 COMPONENT SET is a coordinated cleaning and surface finishing system that produces a very high-quality and long-lasting „easy-to-clean effect“ on glass and ceramic surfaces. The applied material creates a thin film on the surface that reduces the adhesion of dirt and foreign substances and allows water to run off better.

- Small scratches can be polished out with toothpaste and a soft cloth, for example.
- Make sure that the drains, which are located centrally below the back walls in the shower tray, are always open. If they become blocked, the water will no longer run back into the inside of the tub. There is a risk that too much water will accumulate and then run out over the protective wall.
- The prefabricated shower enclosure must always be kept clean to avoid bacterial contamination!
- For hygienic reasons, we recommend that the sealing strips be replaced once a year.

Order „Lotus -Effect Set“ at:

E-mail:	kundenservice@seniorbad.de
Online shop:	www.seniorbad.de
Phone:	+49 35795 - 179 600
Fax:	+49 35795 - 179 699

Tips for descaling the steam generator

The steam generator (SG) must be decalcified often and regularly if the water contains lime. The following steps should be followed:

- Turn off the water and electricity to the shower
- Move shower forward
- Disconnect the SG from electricity and water connections
- Detach the SG from the shower
- Fill commercially available descaler (note manufacturer's instructions!) into the metal tube (steam outlet).
- Allow to soak in, rinse thoroughly and reassemble.
- Carry out at least 3 idle runs for about 5-10 minutes with the window open and the shower door open, switching the shower off completely in between so that the steam generator empties and cools down for a few minutes.
- Caution: As long as there are residues of the descaler in the steam generator, do not use it. Take a steam bath!

!!!! Only operate steam generator hanging correctly !!!!!

Security information on the use of Bluetooth devices

Bluetooth connections can be the target of an attack, through which personal data on the device such as stored text messages, emails, diaries or the phone book can be spied out. Misuse of the device, such as unauthorised phone calls at the expense of others, is also conceivable.

Security measures

- Update the operating system of your Bluetooth-enabled devices at regular intervals
- Always deactivate the Bluetooth interface after use
- Do not pair with unknown devices
- Switch to invisible mode when activating Bluetooth

- Do not authorise any data transmission from unknown sources
- Install malware protection on your Bluetooth devices

Warranty and service

The warranty is based on the current legal regulations from the date of purchase. Parts subject to wear and tear such as lighting, fuses, pumps, electrical components, mixer cartridge, rollers, hand shower, shower hoses, etc. as well as components resulting from negligence, improper use, wear and tear - due to incorrect cleaning, water containing too much lime/iron, incorrect installation or assembly, maintenance, transport damage, overvoltage - are excluded from any warranty. Ignoring the points listed in these operating instructions for the installation, maintenance and operation of the AcquaVapore products also voids the warranty.

Transport damage, operating errors and installation or assembly errors are not covered by the warranty.

All components that were also assembled during installation must always be replaced by the customer, including fuses, operating elements, mixer cartridges, etc. If there is no warranty obligation, the current customer service rates will be invoiced.

Spare parts can be ordered from our customer service. Please describe the spare part exactly - preferably add the abbreviated designation (letter/number) used in this booklet as well as the exact type of cabin (e.g. D37). We are always open to your comments and suggestions.

Note

Every fifth shower enclosure is assembled, connected, tested and repacked at the factory for testing purposes. As our products are subjected to several checks during manufacture, small amounts of residual water may be present in parts of the product. Water may also escape if the shower enclosures are directly irradiated with water.

Despite modern fitting systems, dripping is possible with the various shower systems. With low shower trays, small amounts of water can remain in the shower tray.

Recycling of electrical and electronic appliances

Information for private households

The Electrical and Electronic Equipment Act (ElektroG) contains a large number of requirements for the handling of electrical and electronic equipment. The most important ones are summarised here.

1. Separate collection of old appliances

Electrical and electronic equipment that has become waste is referred to as waste equipment. Owners of old appliances must dispose of them separately from unsorted municipal waste. In particular, old appliances do not belong in household waste, but in special collection and return systems.

As a rule, owners of old appliances must separate used batteries and accumulators that are not enclosed by the old appliance before handing them in at a collection point. This does not apply if the waste equipment is handed in to public waste management authorities and separated there from other waste equipment for the purpose of preparing it for reuse.

2. Options for the return of waste appliances



Owners of old appliances from private households can hand them in at the collection centres of the public waste disposal authorities or at the take-back points set up by manufacturers or distributors within the meaning of the ElektroG.

3. Data protection notice

Old appliances often contain sensitive personal data. This applies in particular to information and telecommunications technology devices such as computers and smartphones. In your own interest, please note that each end user is responsible for deleting the data on the old appliances to be disposed of.

4 Meaning of the „crossed-out wheeled bin“ symbol



The symbol of a crossed-out wheeled bin regularly shown on electrical and electronic equipment indicates that the respective device must be collected separately from unsorted municipal waste at the end of its service life.

5. Producer registration number

As a manufacturer within the meaning of the ElektroG, we are registered with the responsible Stiftung Elektro-Altgeräte Register (Nordostpark 72, 90411 Nuremberg) under the following registration number: WEEE-Reg. No. DE65757710

EU-Konformitätserklärung



gemäß folgenden EU-Richtlinien:

- 2014/35/EU EU-Niederspannungs-Richtlinie/ Low Voltage Directive**
- 2014/30/EU Elektromagnetische Verträglichkeit von Elektro- und Elektronikprodukten/
Electromagnetic Compatibility Directive**
- 2014/53/EU Funkgeräterichtlinie / Radio Equipment Directive**

Hiermit erklären wir, dass die nachstehenden bezeichneten Produkte in ihrer Konzeption und Bauart sowie in der von uns in Verkehr gebrachten Ausführung den grundlegenden Sicherheits- und Gesundheitsanforderungen der EU-Richtlinien entsprechen. Bei einer mit uns nicht abgestimmten Änderung des Produktes verliert diese Erklärung ihre Gültigkeit.

Hersteller:

SeniorBad GmbH
Grenzstraße 11
01936 Laußnitz
Deutschland
Tel. : 035795 - 179 600
E-Mail: info@seniorbad.de

Die alleinige Verantwortung für die Ausstellung dieser Konformitätserklärung trägt der Hersteller.

Produktmodelle: D37, D38, D46, D58, D60, K05

Die oben genannten Produktmodelle verwenden folgende harmonisierte Normen und erfüllen damit die Anforderungen zur CE- Kennzeichnung:

- 2014/35/EU EU-Niederspannungs-Richtlinie/ Low Voltage Directive**
EN IEC 60335-2-105:2021+A11:2021,
EN 60335-1:2012+A11:2014+A13:2017+A1:2019+A14:2019+A2:2019+A15:2021
EN 62233:2008
- 2014/30/EU Elektromagnetische Verträglichkeit von Elektro- und Elektronikprodukten/
Electromagnetic Compatibility Directive**
EN IEC 55014-1:2021, EN IEC 61000-3-2:2019+A1:2021, EN 61000-3-3:2013+A1:2019+A2:2021
EN IEC 55014-2:2021
- 2014/53/EU Funkgeräterichtlinie / Radio Equipment Directive**
EN IEC 62368-1:2020+A11:2020, EN 62479:2010, EN 301 489-1 V2.2.3, EN 301 489-17 V3.2.4
EN 300 328 V2.2.2

Erfüllung aller Vorgaben laut Richtlinie.

Verantwortlicher Geschäftsführer
Alexander Jehlho

Stand 02.04.2024